

## SECTION 1

## Question 1

(1 mark)

A bar magnet is brought towards a loop of copper wire as shown below.

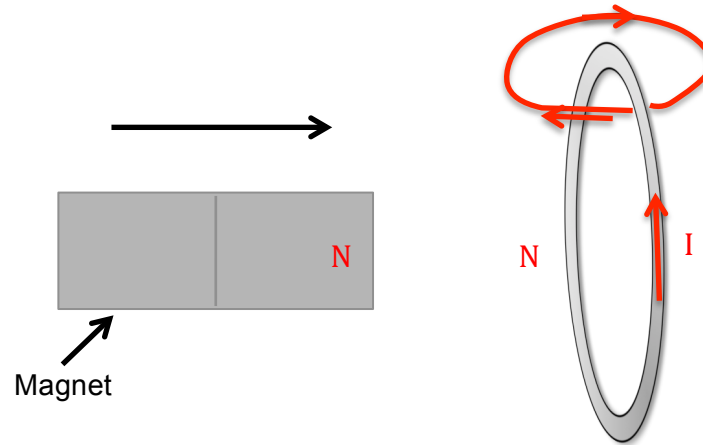

Label the diagram to show the polarity of the magnet if a clockwise current is set up in the loop, as viewed from the magnet.

Magnet only needs to be labelled

## Question 2

(3 marks)

The starting gun of a race is fired directly upwards into the air. The bullet reaches a height of 187 m. Calculate the initial velocity of the bullet.

$$v^2 = u^2 + 2as \quad (1)$$

$$u^2 = 2 \times 187 \times 9.8 \quad (1)$$

$$u = 60.5 \text{ ms}^{-1} \text{ upwards} \quad (1)$$

**Question 3****(3 marks)**

Many comparisons can be drawn between gravitational fields and electric fields. Complete the table below to compare them.

	Gravitational fields	Electric fields
<u>Creates field / acts on</u>	mass	<u>Charged particles</u>
Field strength symbol	<u>g</u>	<u>E</u>
<u>Units</u>	<u>ms<sup>-2</sup></u>	NC <sup>-1</sup>

½ mark each box

**Question 4****(3 marks)**

A golfer uses a computer model to analyse how he approaches each hole on the course. The computer model does not account for air resistance. Describe how the theoretical predictions will be different from the shots he plays in reality.

Theoretical model will be:

- symmetrical parabola
- longer than the real shot
- higher than the real shot

**Question 5****(5 marks)**

Explain why a snowboarder feels a change in their weight when travelling in a half pipe as shown below.



- The sense of weight is given by the normal force pushing up on you
- When the snowboarder is at the bottom of the half pipe he is moving in a circular path
- The sum of forces acts towards the centre of the circle
- The normal force must increase to balance the weight and to provide the centripetal force
- As the normal force is greater the snowboarder feels heavier

**Question 6****(5 marks)**

A 30.0 cm length of aluminium wire is placed between two magnets, which set up a magnetic field of 5.40 T, as seen from one end in the diagram below. The wire is connected to an external circuit so that a current flows through it. When this happens the wire moves with a force of 1.36 N to the left, as seen from the end of the wire.

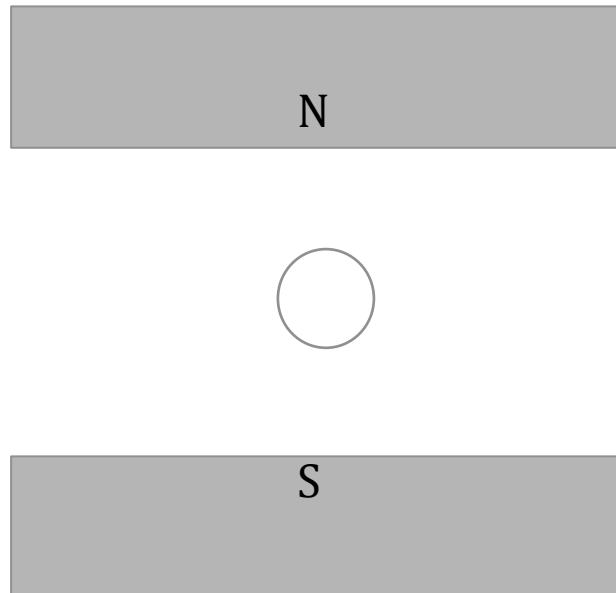

- (a) Calculate the current that flows through the wire.

(3 marks)

$$F = ILB \quad (1)$$

$$I = 1.36 / (5.40 \times 0.3) \quad (1)$$

$$I = 0.840 \text{ A into the page} \quad (1)$$

- (b) On the diagram, sketch the resulting field when the current is flowing.

(2 marks)

1 mark shape  
1 direction

**Question 7****(5 marks)**

Helicopters are used to carry out rescue operations from remote places, as shown in the picture below, where an adult male is being lifted to safety.



Based on the information in the picture, estimate the rotational velocity of the outer tip of rotor blades, if rotate at 7.50 revolutions per second.

Estimate of person's height: 1.5 – 2 m (1)

Rotor radius = 3 x person = 4.5m – 6 m (1)

$$T = 1 / f \quad (1/2)$$

$$T = 0.133 \text{ s} \quad (1/2)$$

$$V = d / t \quad (1/2)$$

$$V = 2\pi r / T \quad (1/2)$$

Accept an answer between the following two values:

$$V_{\min} = 2 \times \pi \times 4.5 / 0.133 = 210 \text{ ms}^{-1}$$

$$V_{\max} = 2 \times \pi \times 6 / 0.133 = 280 \text{ ms}^{-1} \quad (1)$$

**Question 8****(3 marks)**

A fisherman is standing on the end of a jetty, with a large fish caught on the end of his line. The fisherman finds he needs to lean backwards as he reels in the fish so that he does not fall into the water. Explain why he needs to lean backwards.

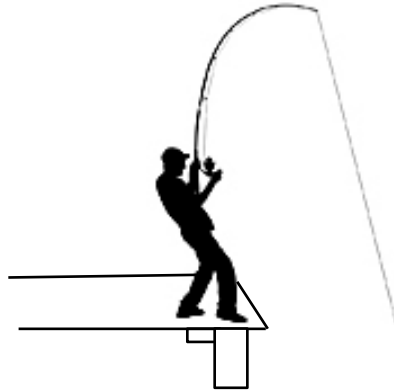

The fish on the end of the line provides a clockwise torque (1)

The pivot point is the man's feet ( $\frac{1}{2}$ )

The man moves his centre of mass backwards ( $\frac{1}{2}$ )

to provide an anti-clockwise torque (1)

**Question 9****(4 marks)**

A length of wire is shaped into a coil and placed in a magnetic field of flux density 7.22 mT as shown below.

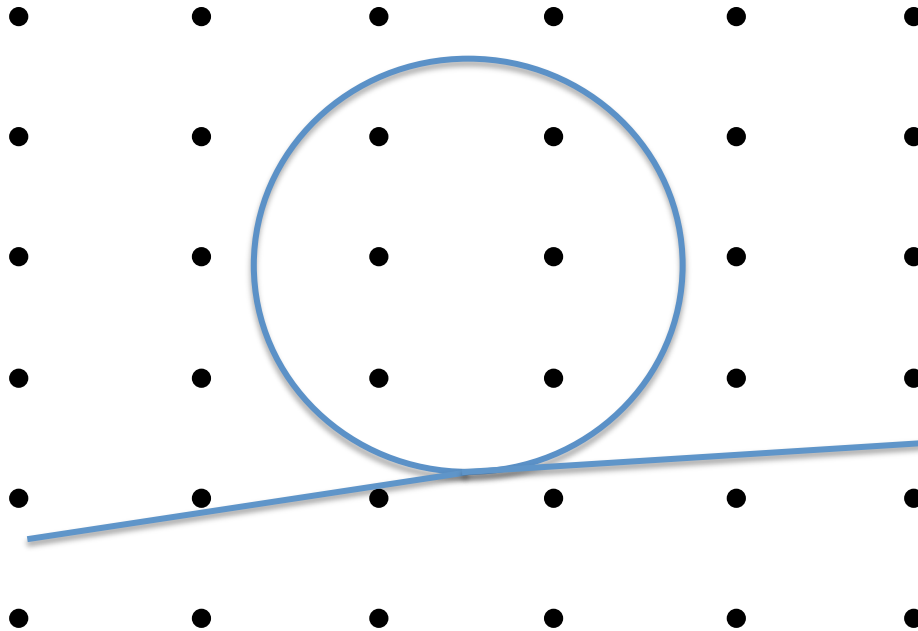

Initially the loop has an area of 4.65 cm<sup>2</sup> but it is then pulled and tightened until it has an area of 3.25 cm<sup>2</sup>. The loop is tightened in a time of 0.300 s.

Calculate the magnitude of the e.m.f. generated in the coil.

$$\phi = BA \quad (1)$$

$$\varepsilon = \Delta \phi / \Delta t \quad (1)$$

$$\varepsilon = B(A_2 - A_1) / t$$

$$\varepsilon = 7.22 \times 10^{-3} ((4.65 - 3.25) \times 10^{-4}) / 0.3 \quad (1)$$

$$\varepsilon = 3.37 \times 10^{-6} \text{ V} \quad (1)$$

**Question 10****(3 marks)**

A solenoid is connected to a cell as shown below. Complete the diagram to show the magnetic field associated with the solenoid including labels of the poles.

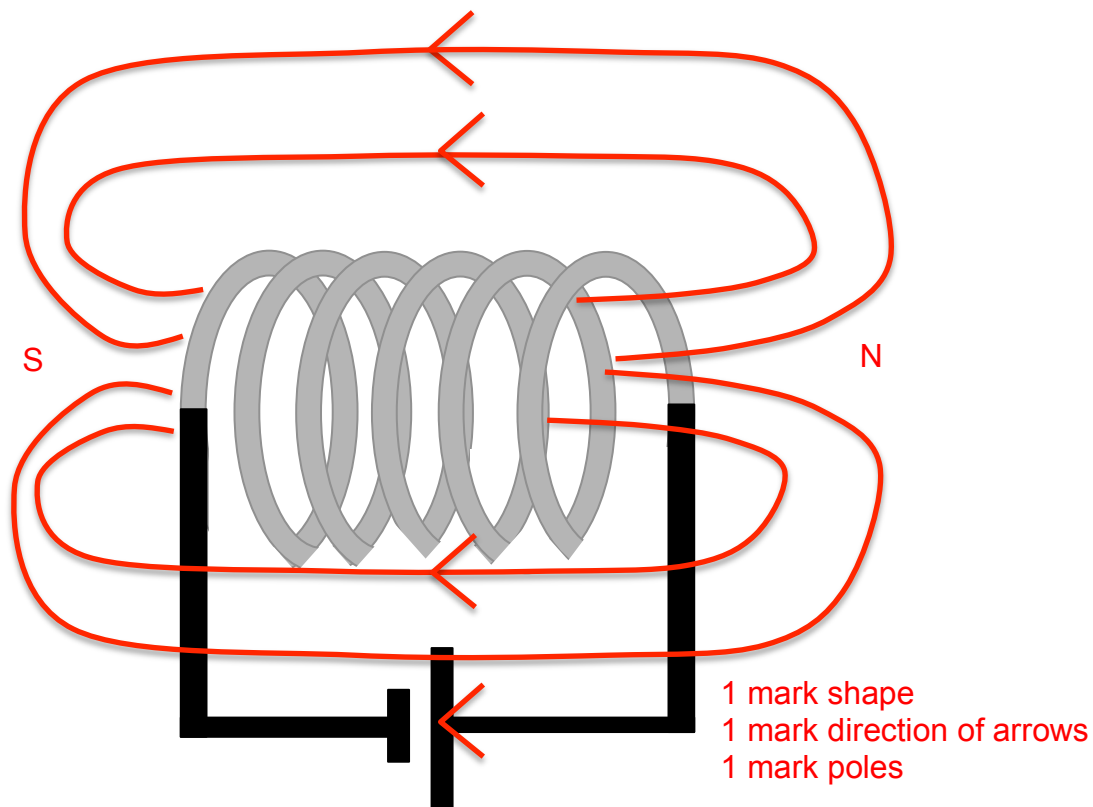
**Question 11****(4 marks)**

An alpha particle (made up of 2 protons and 2 neutrons) is in the middle of two conducting plates that are 4.00 cm apart. The plates are then connected to an external circuit so that they have a potential difference of 7.50 V across them.

Calculate the magnitude of the force exerted on the alpha particle.

$$\textcircled{1} \quad E = \frac{F}{q} \quad E = \frac{V}{d} \quad \textcircled{1}$$

$$F = \frac{Vq}{d}$$

$$F = \frac{7.50 \times 2 \times 1.6 \times 10^{-19}}{0.04} \quad \textcircled{1}$$

$$F = 6.00 \times 10^{-17} \text{ N} \quad \textcircled{1}$$



**Question 12****(4 marks)**

The Earth's magnetic field is stronger at some places than others. Making reference to a labelled diagram state where the field is strongest and which aspect of your diagram shows this.

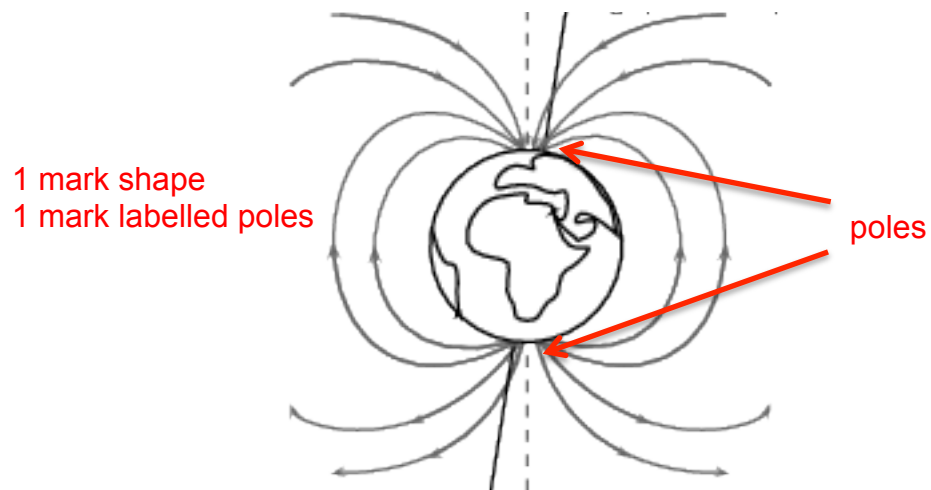

- The Earth's magnetic field is strongest at the poles

- This is shown by the lines, which are denser at the poles
- 
- 
- 
-

**Question 13****(4 marks)**

A 2.00 kg mass is held on a rope attached to a light spring balance as shown in the diagram below. It is then swung in a vertical circle of radius of 1.50 m. Calculate the force the spring balance reads at the lowest point in the circle if it is moving at  $4.00 \text{ ms}^{-1}$  at this point.

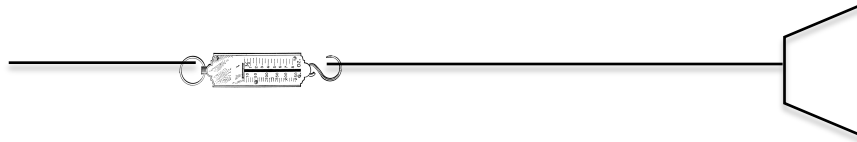

$$\Sigma F = ma \quad \left(\frac{1}{2}\right)$$

$$\Sigma F_v = T - mg = \frac{mv^2}{r}$$

$$T = mg + \frac{mv^2}{r} \quad \left(\frac{1}{2}\right)$$

$$= (2)(9.8) + \frac{(2)(4^2)}{1.5} \quad (1)$$

$$= 40.9 \text{ N} \quad \text{Upwards}$$

$$(1)$$

$$(1)$$

**Question 14****(7 marks)**

In the movie *Total Recall* featuring Arnold Schwarzenegger, human habitations exist on the surface of the planet Mars. In one scene, a 5.00 kg object is dropped from the top of a building reaching a speed of  $11.2 \text{ ms}^{-1}$  in a time of 3.00 seconds.

- (a) Calculate the acceleration due to gravity near the surface of Mars. (3 marks)

$$a = \frac{v - u}{t} \quad (1)$$

$$a = \frac{11.2 - 0}{3} \quad (1)$$

$$a = 3.37 \text{ ms}^{-2} \quad (1)$$

- (b) Given that Mars has a radius of 3430 km, calculate the mass of Mars. (4 marks)

$$g = \frac{Gm}{r^2} \quad (1)$$

$$m_m = \frac{3.37 \times (3430 \times 10^3)^2}{6.67 \times 10^{-11}} \quad (2)$$

$$m_m = 5.94 \times 10^{23} \text{ kg} \quad (1)$$

**End of Section One**

## SECTION 2

## Question 1

(10 marks)

The human arm is a lever, with the bicep muscle pulling the forearm in an upwards direction. The following diagram shows a person exercising with a heavy ball.

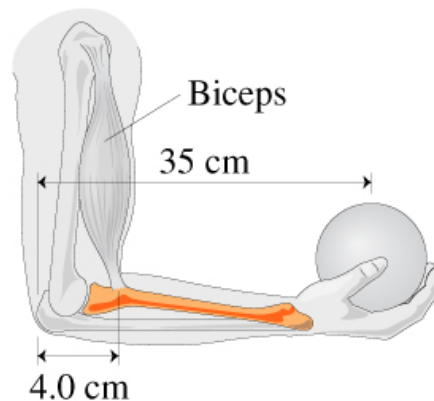

If the forearm is considered to be uniform the centre of mass will be 17.5 cm from the elbow joint. The mass of the forearm is 1.70 kg. The ball that the person is holding is 4.00 kg.

- (a) Calculate the magnitude of tension in the bicep muscle necessary to hold the forearm horizontal.

(4 marks)

$$\Sigma T_{cw} + \Sigma T_{acw} = 0 \quad (1)$$

$$\tau = Fr \sin \theta \quad (1)$$

Take elbow as pivot

$$(T_B \times 4) = (1.7 \times 9.8 \times 17.5) + (35 \times 4 \times 9.8) \quad (1)$$

$$T_B = 416 \text{ N} \quad (1)$$

The person then performs a bicep curl, where they raise their hand from position B to A, so that the angle at the elbow joint decreases, then lower their hand past the starting position to C as shown in the diagram below.

A

B

C



- (b) State which position (A, B or C) feels the most difficult to hold stationary and explain your reasoning.

(4 marks)

- Position B / horizontal

- 
- Torque is the product of the force and the perpendicular distance to the pivot point (the elbow in this case)
- 

- In position B, the perpendicular distance between the ball and the elbow is the greatest so (clockwise) torque increase
- 

- Bicep must provide a greater torque in the opposite (anticlockwise) direction to counter this
- 

The biceps form a muscle pair group with the triceps. When the triceps contract and shorten, the biceps relax and lengthen, and vice versa. The triceps are also connected to the forearm by tendons as shown below.

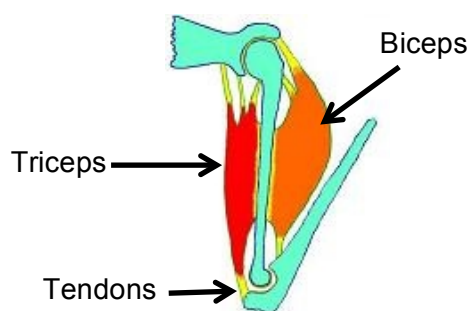

- (c) Explain the role of the triceps in bringing the forearm to its lowest position.

(2 marks)

- Triceps shorten and pull on the forearm
- 

- This creates a rotational effect in the opposite direction pulling the forearm down
-



**Question 2****(13 marks)**

A boy standing at the top of a bridge throws a \$2 coin downward at an angle of  $60.0^\circ$  below the horizontal. The top of the bridge is  $50.0\text{ m}$  above the water level and the initial speed of the coin is  $40.0\text{ ms}^{-1}$ .



- (a) Calculate the time for the coin to reach the surface of the water. (4 marks)

$$s = ut + \frac{1}{2}at^2 \quad (1)$$

$$-50 = (-40 \sin 60)(t) + \frac{1}{2}(-9.8)(t^2) \quad (1)$$

$$4.9t^2 + 34.6t - 50 = 0$$

$$t = \frac{-34.6 \pm \sqrt{(-34.6)^2 - (4)(4.9)(-50)}}{(2)(4.9)} \quad (1)$$

$$= 1.23\text{ s} \quad (1)$$

- (b) A duck is floating  $15.0\text{ m}$  from where the boy stands on the bridge. With the aid of a calculation, determine if the coin will hit the duck. (3 marks)

$$\begin{aligned} s &= tv \quad (0.5) \\ &= (1.23)(40 \cos 60) \quad (0.5) \\ &= 24.6\text{ m} \quad (1) \end{aligned}$$

No  $24.6 > 15$  the coin will not hit the duck

(0.5 marks for 'no')

(1)

(c) If the boy had thrown the coin upwards at  $60.0^\circ$  to the horizontal, with the same initial speed;

(i) would this have changed the distance between where the coin landed and where it was thrown? Explain your reasoning.

(3 marks)

- Yes

---

- Throwing the coin upwards initially will increase the time between it

---

leaving the boy's hand and it landing on the water's surface.

---

- In this time the coin will have travelled a greater distance in the

---

horizontal direction.

---

(ii) would this have changed the final vertical speed of the coin? Explain your reasoning.

(3 marks)

- No

---

- When the coin reaches the level of the boy's hand when moving

---

downwards, it will be travelling at  $40\sin 60^\circ$  downwards.

---

- As this is the same as in the original scenario and the coin still

---

travels through the same vertical distance from the hand to the

---

water, the final vertical speed will not change.

---





**Question 3****(26 marks)**

The diagram below shows two charged horizontal plates.

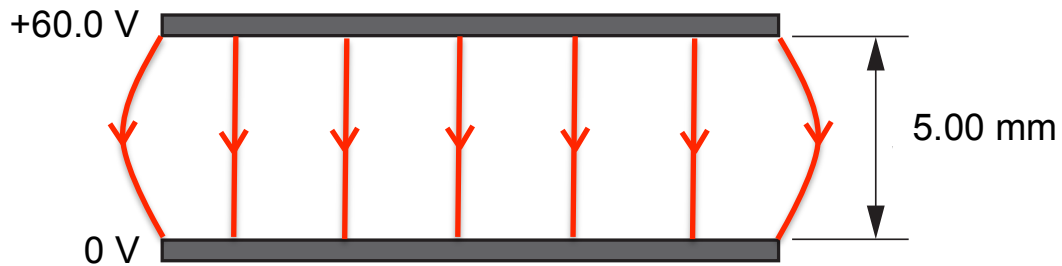

The potential difference across the plates is 60.0 V. The separation of the plates is 5.00 mm.

- (a) On the diagram draw the electric field pattern between the plates. (2 marks)

Evenly spaced, straight lines, curved edges (1)

Arrows correct way (1)

- (b) Calculate the electric field strength between the plates. (3 marks)

$$E = V / d \quad (1)$$

$$E = 60.0 / 5.00 \times 10^{-3} \quad (1)$$

$$E = 12000 \text{ V m}^{-1} \quad (1)$$

Positive ions are accelerated from rest in the horizontal direction through a potential difference of 400V. The charged plates are then used to deflect the ions in the vertical direction. The path of these ions is shown below.

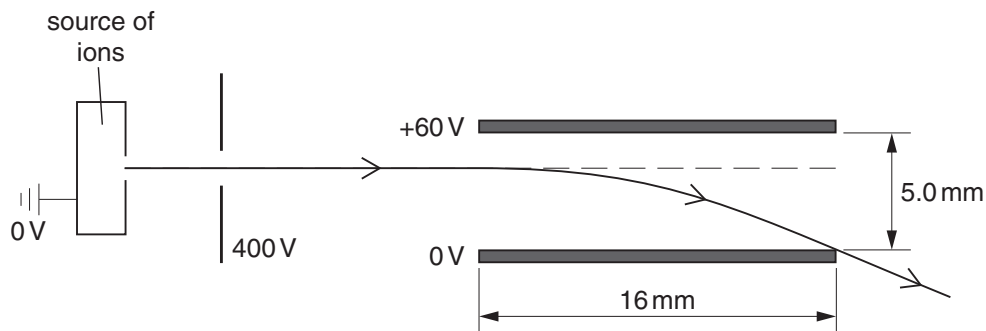

Each ion has a mass of  $6.60 \times 10^{-27}$  kg and a charge of  $3.20 \times 10^{-19}$  C.

- (c) Show that the horizontal velocity of an ion after the acceleration by the 400V potential difference is approximately  $2.00 \times 10^5$  m s<sup>-1</sup>. (4 marks)

$$E_k = \frac{1}{2}mv^2 \quad (1)$$

$$W = Vq \quad (1)$$

$$v = \sqrt{\frac{2Vq}{m}} \quad (1)$$

$$v = \sqrt{\frac{2 \times 400 \times 3.20 \times 10^{-19}}{6.60 \times 10^{-27}}} = 1.97 \times 10^5 \text{ ms}^{-1} \quad (1)$$

The ions enter the space between the plates at right angles to the uniform electric field.

- (d) Calculate the vertical acceleration of an ion due to this electric field. (3 marks)

$$F = ma \quad (1/2)$$

$$F = Eq \quad (1/2)$$

$$a = Eq / m$$

$$a = (12000 \times 3.20 \times 10^{-19}) / 6.60 \times 10^{-27} \quad (1)$$

$$a = 5.82 \times 10^{11} \text{ m s}^{-2} \quad (1)$$

The length of each of the charged plates is 16.0 mm.

- (e) Calculate the time that an ion takes about to travel through the plates.  
(3 marks)

$$s = vt \quad (1)$$

$$t = 16 \times 10^{-3} / 1.97 \times 10^5 \quad (1)$$

$$t = 8.12 \times 10^{-8} \text{ s} \quad (1)$$

- (f) Calculate the vertical deflection of an ion as it travels through the plates.  
(3 marks)

$$s = ut + \frac{1}{2} at^2 \quad (1)$$

$$= \frac{1}{2} (5.82 \times 10^{11} \times (8.12 \times 10^{-8})^2) \quad (1)$$

$$= 1.92 \times 10^{-3} \text{ m} \quad (1)$$

A uniform magnetic field is applied in the region between the horizontal plates. The magnetic field is perpendicular to both the path of the ions and the electric field between the plates.

- (g) Calculate the magnitude of the magnetic flux density of field needed to make the ions travel horizontally through the plates.

(4 marks)

$$F = qvB \quad (1) \qquad F = Eq \quad (1)$$
$$B = E/v = 12000 / 1.97 \times 10^5 \quad (1)$$
$$= 6.09 \times 10^{-2} \text{ T} \quad (1)$$

Ions of the same charge but greater mass are accelerated by the potential difference of 400 V described above.

- (h) Describe and explain the effect on the deflection of the ions as they are travelling between the plates using the same electric and magnetic fields given above.

(4 marks)

- The heavier ions will have a lower velocity
- so the magnetic force they experience will be less as  $F = qvB$ .
- The force due to the electric field is unchanged
- so the beam deflects down towards the plate of lower potential.

**Question 4****(11 marks)**

The Millennium Dome in London is a large marquee, held up by 12 support towers that are 100 m in length from the ground to their tip.



*Photograph of the Millennium Dome*

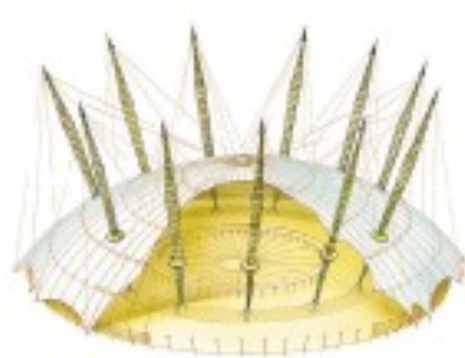

*Diagram showing the Dome's internal structure*

A simplified diagram of a single support tower is shown below.

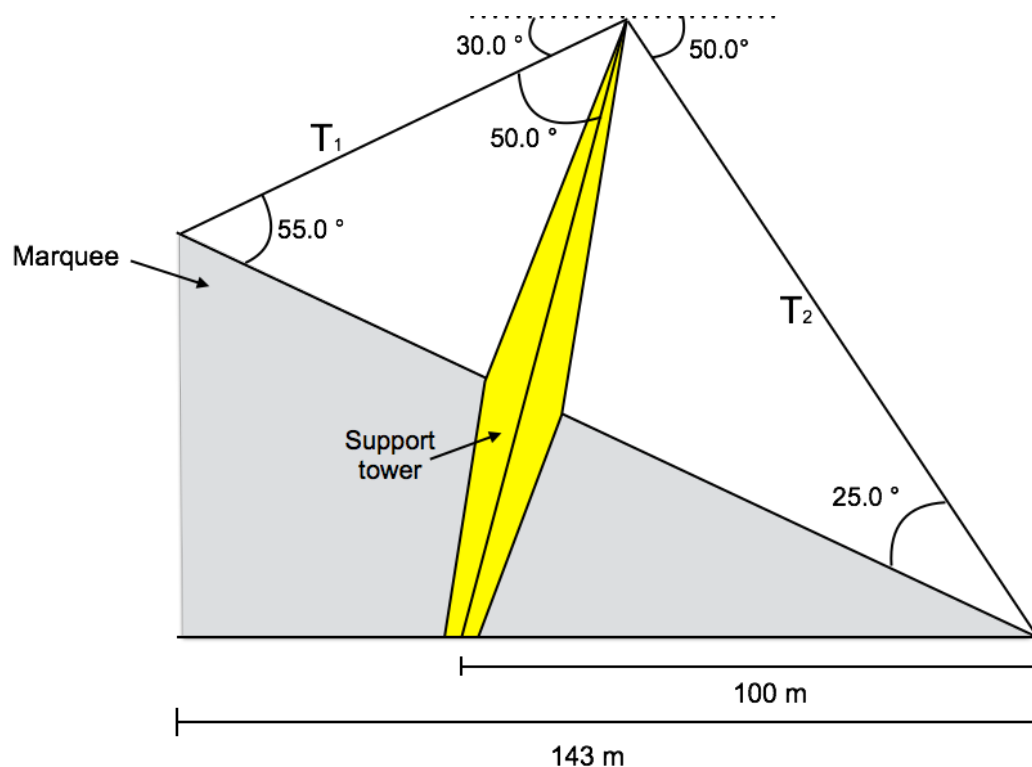

The support tower goes through a hole in the marquee surface and is attached to the ground, at a distance of 100 m from the base of the marquee. The support tower is held in place by two lengths of steel cable,  $T_1$  and  $T_2$ , which are at angles of  $30.0^\circ$  and  $50.0^\circ$  to the horizontal, respectively.  $T_2$  connects at the base of the marquee and  $T_1$  connects at a point on the

marquee 143 m from the base. The mass of a single support tower is  $8.00 \times 10^4$  kg.

- (a) Calculate the force the ground exerts on the support tower if the magnitude of tension in the cables is  $T_1 = 6.40 \times 10^5$  N and  $T_2 = 4.50 \times 10^5$  N.

(6 marks)

$$\Sigma F = 0 \quad (1)$$

$$\Sigma F_H = T_{1H} + T_{2H} + F_{GH} = 0$$

$$6.40 \times 10^5 (\cos 30) - 4.50 \times 10^5 (\cos 50) + F_{GH} = 0 \quad (1/2)$$

$$F_{GH} = 2.65 \times 10^5 \text{ N (left / towards centre of dome)} \quad (1)$$

$$\Sigma F_V = F_N - mg - T_{2V} - T_{1V} = 0$$

$$F_N = 4.50 \times 10^5 (\sin 50) + 6.40 \times 10^5 (\sin 30) + (8.00 \times 10^4 \times 9.8) \quad (1/2)$$

$$F_N = 1.45 \times 10^6 \text{ N (up)} \quad (1)$$

$$\text{Total ground force} = \sqrt{(2.65 \times 10^5)^2 + (1.45 \times 10^6)^2} = 1.47 \times 10^6 \text{ N} \quad (1/2)$$

$$\theta = \tan^{-1} \left( \frac{1.45 \times 10^6}{2.65 \times 10^5} \right) = 79.6^\circ \quad (1/2)$$

$$1.47 \times 10^6 \text{ N at } 79.6^\circ \text{ above horizontal to left} \quad (1)$$

- (b) Calculate the horizontal distance from the base of the support tower to its centre of mass.

(5 marks)

$$\Sigma T = 0 \quad (1)$$

$$T = Fr \sin\theta \quad (1/2)$$

$$\Sigma T_{cw} = \Sigma T_{acw} \quad (1/2)$$

Take base of tower as pivot

$$\Sigma T_{cw} = (mg \times r) + (T_2 \times 100 \sin 50) \quad (1/2)$$

$$\Sigma T_{acw} = T_1 \times 100 \sin 50 \quad (1/2)$$

$$(8.00 \times 10^4 \times 9.8 \times r) + (4.50 \times 10^5 \times 100 \sin 50) = (6.40 \times 10^5 \times 100 \sin 50)$$

$$r = \frac{(6.40 \times 10^5 \times 100 \sin 50) - (4.50 \times 10^5 \times 100 \sin 50)}{8.00 \times 10^4 \times 9.8} \quad (1)$$

$$r = 18.6 \text{ m to right of pivot} \quad (1)$$



**Question 5****(15 marks)**

A block of mass 400 g starts from rest at the top of a frictionless ramp, 30.0 cm above the tabletop, as shown in the diagram below. There is a curved vertical wall, of radius  $R$ , at the base of the ramp. It can be assumed that the tabletop is also frictionless.

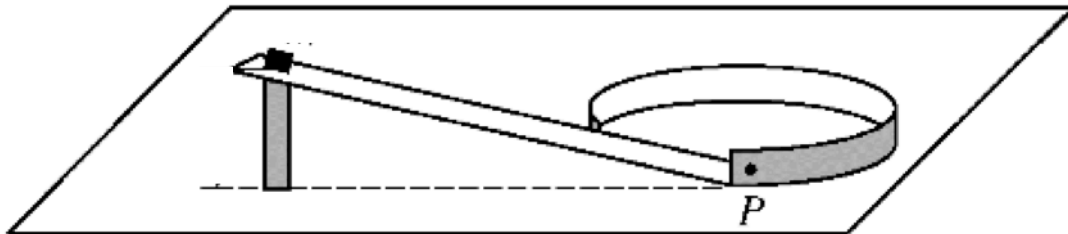

- (a) Calculate the speed of the block when it reaches the bottom of the ramp.

**(4 marks)**

$$\Sigma E_i = \Sigma E_f \quad (1)$$

$$(0.5) \quad E_k = \frac{1}{2}mv^2 \quad E_p = mgh \quad (0.5)$$

$$\frac{1}{2}mu^2 + mgh_i = \frac{1}{2}mv^2 + mgh_f$$

$$\frac{1}{2}(0.4)(0) + (0.4)(9.8)(0.3) = \frac{1}{2}(0.4)(v^2) + (0.4)(9.8)(0) \quad (1)$$

$$v = 2.42 \text{ ms}^{-1} \quad (1)$$

A short time after passing point P, the block is in contact with the wall and moving with a speed  $v$ . There is a frictional force between the wall and the block.

- (b) Is the vertical component of the force on the block? Circle your chosen response. (1 mark)
- (i) Upward
- (ii) Downward
- (iii) Zero

- (c) Explain why you chose your answer to (b). (3 marks)

- The block is in contact with the table so there will be a normal force due to the table acting up on the block.

- There will be the weight force of the block acting downwards through the centre of the Earth.

- As the block is not accelerating in the vertical direction  $F_N = mg$  and so the net force in the vertical direction will be equal to zero.

- (d) On the diagram below, draw an arrow to show the direction of the horizontal component of the net force on the moving block when it is at the position shown below. (2 marks)

1 mark if an arrow to the centre (indicating just Normal force present) or if directly downwards (indicating just friction present).

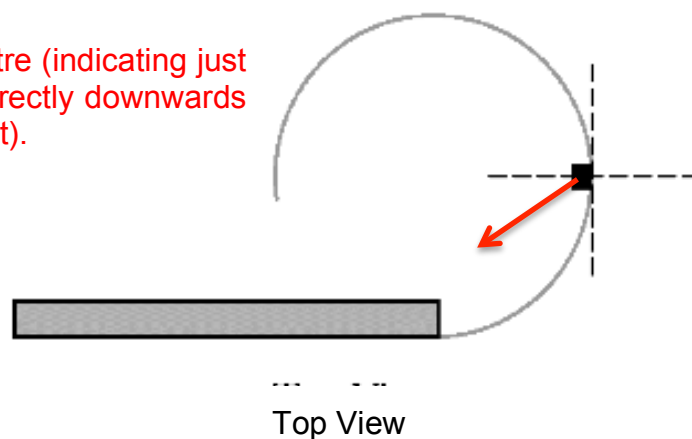

Given that the radius,  $R$ , of the loop is 0.500 m, the coefficient of friction between the loop and block 0.02 and the frictional force between the block and loop is 24.6 mN and making use of the relationship;

$$F_f = \mu F_N$$

(e) Calculate the radial acceleration of the block.

(5 marks)

$$F_f = \mu F_N$$

$$F_N = \frac{24.6 \times 10^{-3}}{0.02} \quad (0.5)$$

$$= 1.23 \text{ N} \quad (1)$$

$$F_c = \frac{mv^2}{r}$$

$$1.23 = \frac{(0.4)(v)^2}{0.5} \quad (0.5)$$

$$a_c = \frac{v^2}{r} = \frac{F_c}{m} = 3.08 \text{ ms}^{-2} \text{ towards the centre of the loop}$$

$$(1) \quad (1) \quad (1)$$

**Question 6****(15 marks)**

A group of students set up an experiment to investigate the relationship between the current flowing through a wire and its interaction with a magnetic field.

The students supported a wire of length 20.0 cm using a newton meter, so they could measure the force. They connected the wire into a DC circuit, then placed a uniform magnetic field around it.

Each time the students switched on the circuit the newton meter briefly gave them a reading of force.

The following data was collected:

Current (A)	Force ( $\times 10^{-3}$ N)
0.00	0.50
0.20	0.71
0.40	0.93
0.60	1.14
0.80	1.36
1.00	1.57

(a) Plot a graph of F vs I on the grid below.

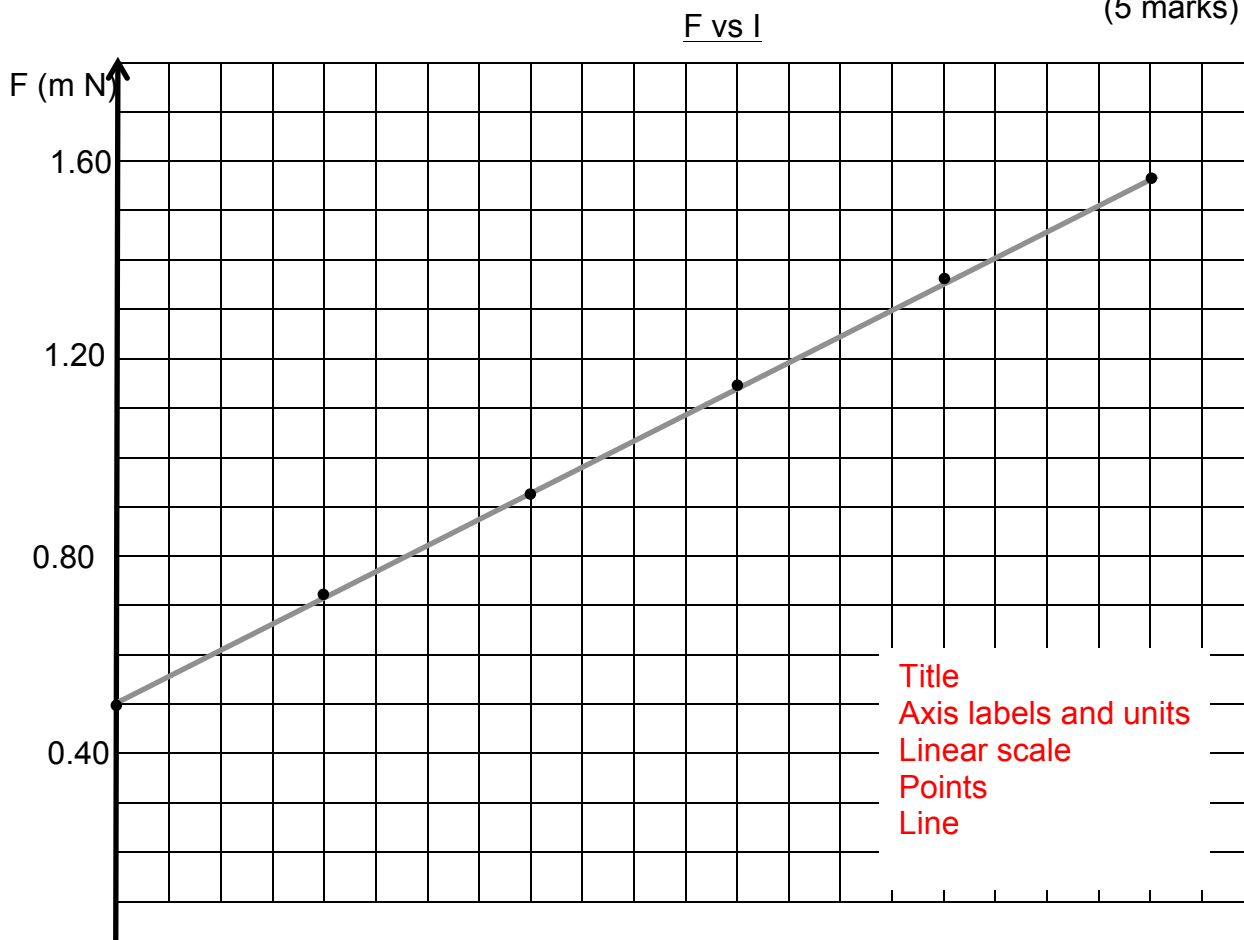
**(5 marks)**

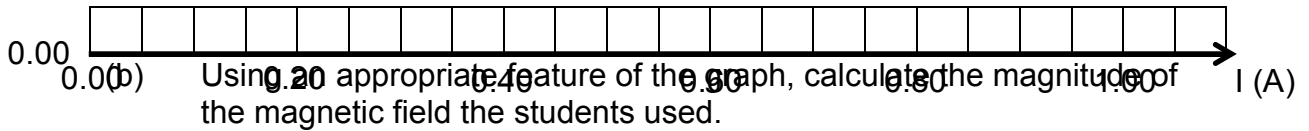

(b) Using appropriate feature of the graph, calculate the magnitude of the magnetic field the students used. (5 marks)

Triangle drawn on graph (1)

Gradient = rise / run

Gradient =  $(1.57 - 0.5) \times 10^{-3} / 1 = 1.07 \times 10^{-3} \text{ NA}^{-1}$  (1)

$F = ILB$  (1)

$F / I = \text{gradient} = LB$

Gradient / L = B (1)

$1.07 \times 10^{-3} / 0.2 = 5.35 \times 10^{-3} \text{ T}$  (1)

(c) State what the y-intercept of the graph represents. (1 mark)

Weight of the wire

(d) The students repeated the experiment with a longer piece of wire. State which aspects of the graph would change and explain your reasoning. (4 marks)

- Y intercept would increase

---

- as wire would be heavier

---

- Gradient would increase

---

- F is directly proportional to L so for the same current and field, more force is experienced

---



---



---

**END OF SECTION  
SECTION 3****Question 1****(19 marks)****The Physics of Washing Machines**

Many of the devices found in our homes use Physics principles in their design and to carry out their job. One such device is the washing machine.

Washing machines can either be a top loader (Figure 1a), where the clothes are spun in a horizontal circle, or a front loader (Figure 1b) where the clothes are spun in a vertical circle.

*Figure 1a: Top loader washing machine**Figure 1b: Front loader washing machine*

Operating a washing machine is simple. There are a few things to decide before you start your load of clothes, such as how big the load is, what temperature the water will be, and how fast the cycle spin is.

**Inside a Washing Machine**

The internal structure of a washing machine has many parts (Figure 2).

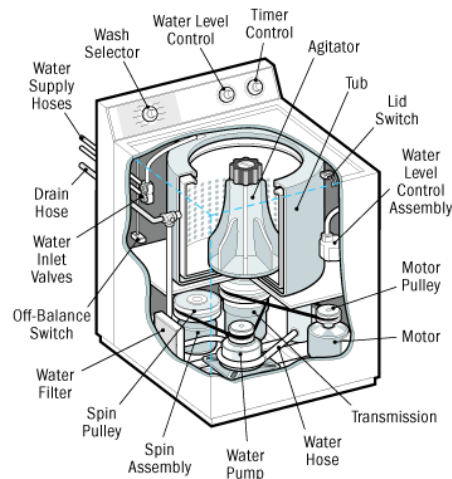

*Figure 2: Diagram of a top loader washing machine.*

Washing machines typically have a large mass and are difficult to move. Figure 3 shows a top loader washing machine viewed from underneath, so that a counter weight, made from a large block of concrete, is visible. The concrete is there to balance a heavy electric motor, which drives an equally heavy gearbox that is attached to the steel inner tub.

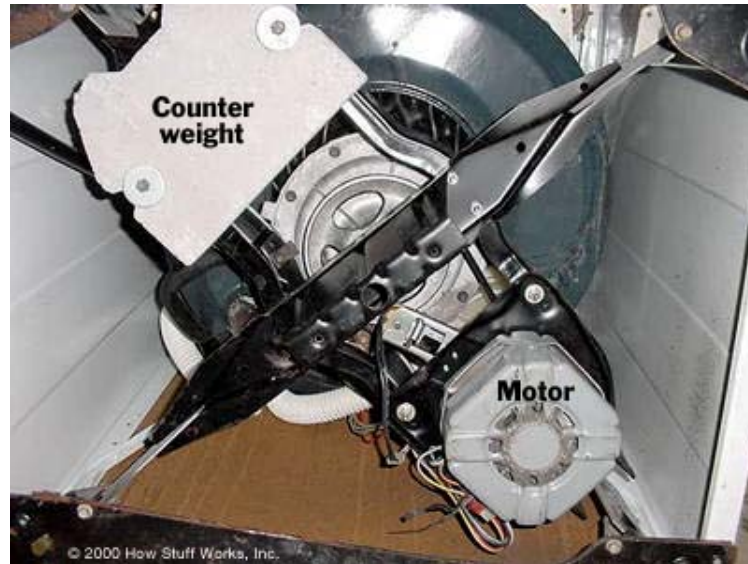

*Figure 3: A top loader washing machine as seen from underneath.*

The washing machine has two steel tubs. The **inner tub** is the one that holds the clothes. It has an **agitator** in the middle of it, and the sides are perforated (has **holes in it**) so that when the tub spins, the water can leave (Figure 4).



*Figure 4: The inside view of a top loader washing machine showing the agitator in the centre, and the perforated inner tub.*

The **outer tub**, which seals in all the water, is bolted to the body of the washer. As the inner tub vibrates and shakes during the wash cycle, it has to be mounted in a way that lets it move around without banging into other parts of the machine. The inner tub is only connected to the rest of the frame by a shaft at its base.

- (a) Explain the location and function of the concrete block found in washing machines.

(3 marks)

- The motor of a washing machine is heavy and does not sit at the centre, causing a tipping effect.

- The concrete block provides torque in the opposite direction,

- Providing a counterweight to the motor.

- (b) The sides of the inner tub are perforated with holes so that water can leave during a spin cycle, as water appears to be flung outwards from the middle of the machine. Use physics principles to explain why this happens.

(2 marks)

- According to Newton's First Law, an object will continue in a straight of uniform motion unless acted on by an external force.

- In this case as the tub spins, the water continues in a straight line path and so hits the wall of the drum.



- (c) The inner tub of the washing machine has a diameter of 52.0 cm and a mass of 2.50 kg. It is filled with 15.0 kg of water during a wash cycle at 840 rpm (revolutions per minute). Calculate the maximum mass of clothes can be placed into the machine if the connection between the inner tub and the frame can withstand a centripetal force of 48.0 kN.  
(4 marks)

$$F_c = \frac{mv^2}{r} \quad \left(\frac{1}{2}\right)$$

$$T = \frac{1}{f}$$

$$840 \text{ rpm} / 60 = 14.0 \text{ Hz} \quad \left(\frac{1}{2}\right)$$

$$v = \frac{2\pi r}{T} \quad \left(\frac{1}{2}\right)$$

$$v = 2 \times \pi \times (0.52 / 2) \times 14 = 22.9 \text{ ms}^{-1} \quad \left(\frac{1}{2}\right)$$

$$48000 = \frac{m(22.9^2)}{0.26}$$

$$m = 23.80 \text{ kg} \quad (1)$$

$$23.8 - 15 - 2.5 = 6.30 \text{ kg clothes} \quad (1)$$

- (d) Explain why a front loader washing machine would be more likely to break whilst washing a heavy load than a top loader machine would.  
(5 marks)

- In a front loading washing machine the tub spins vertically,

---

compared to the horizontal spin of a top loader.

---

- The tub of the front loader has to provide enough force at the bottom of the spin
- 

- to overcome the weight force
- 

- and provide centripetal force to keep the clothes moving in a circular path
- 

- If the shaft can't provide the force it will break
-

## Plumbing

The **plumbing** on the washing machine has several jobs but the most important is filling the washing machine with the correct temperature of water.

The washing machine has hookups for **two water lines** on the back, one for hot water and one for cold. These lines are hooked up to the body of a **solenoid valve**. A solenoid valve, otherwise known as an electrically-operated valve is an automatic valve which serves the purpose of removing the need for a valve to be operated manually.

You can see that there are **two valves**, but they feed into a **single hose**. So depending on the **temperature** selected, either the hot valve, the cold valve or both valves will open.

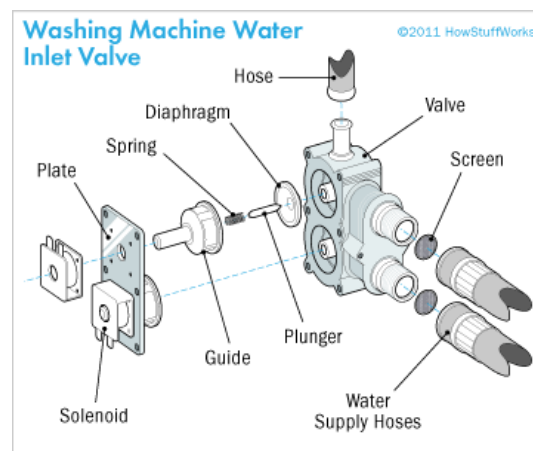

Solenoids operate using an electromagnetic solenoid coil to change the state of a valve from open to closed, or vice-versa. If the solenoid valve is 'normally closed', when a current flows through the coil, the valve gets lifted open.

When the washing machine enters a cycle where water of a different temperature must be added to the tub, a dial automatically turns and in doing so closes a switch that allows electric current to flow in one direction through the solenoid. When enough water of that temperature has been added, the dial turns again and either disconnects the solenoid or allows current to flow the opposite way.

- (e) The solenoid from the valve system is shown below. If current flows anticlockwise when looking from A, sketch the magnetic field. (2 marks)

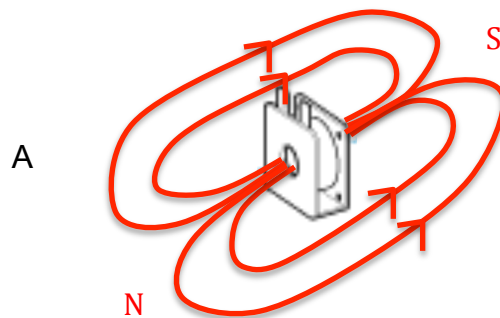

- 1 mark for shape and arrows
- 1 mark for direction and poles label

- (f) The guide, which is connected to the plunger, is made of soft iron. Making reference to your diagram in (e) explain how the valve is closed. (3 marks)

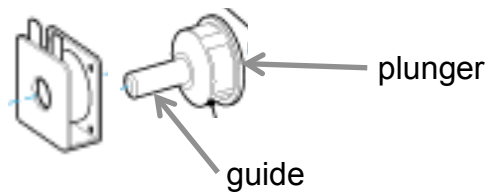

- When current flows in the solenoid it sets up a magnetic field in the shape of a bar magnet as shown in the diagram
- The domains in the soft iron core align with the external field and are attracted to the solenoid when it is switched on
- When the solenoid is switched off the plunger returns to its original position which is closed

**Question 2****(17 marks)****Jupiter's Magnetosphere: The Largest in Our Solar System**

Interplanetary space was once believed to exist in a vacuum as empty space - but, due to the many discoveries throughout the past several decades, we now know that is not the case. Interplanetary space contains two primary constituents - the solar wind and planetary magnetospheres. The planet Jupiter has a particularly interesting magnetosphere.

The first clue to Jupiter's extraordinary magnetic field came with the detection of strong radio frequency emissions from the planet. When spacecraft reached the vicinity of Jupiter, they found that its magnetosphere was about 30 million km across, larger than the entire Sun.

From analysis of the radio frequency emissions, it is implied that the magnetic pole strength of Jupiter is nearly 20,000 times stronger than the Earth's pole strength, but that it lies a significant distance below the surface of the planet. The surface magnetic fields are not that much stronger than those of Earth. It is thought that the surface magnetic field strengths are about 0.00004 T at Jupiter's equator.

Io, the closest of the moons of Jupiter, is about the size of Earth's moon but in relation to the planet's diameter, it is much closer to Jupiter. Its orbital radius is just 5.90 times the radius of Jupiter, and so puts it in a region of intense magnetic field. It has a significant and unique effect on the magnetosphere of the planet. Io has a mass of  $8.93 \times 10^{22}$  kg.



*Photograph showing Io and its shadow passing Jupiter, taken by the Cassini Imaging Team.*

Io's effect is significant because of its intense volcanism. The particles ejected by Io's volcanoes have interacted with the magnetic field of the planet to produce a ring of charged particles around the planet, following Io's orbit. It is referred to as the Io plasma torus. This torus is detectable from Earth, but its origin was unknown until Voyager discovered the intense volcanic activity of Io.

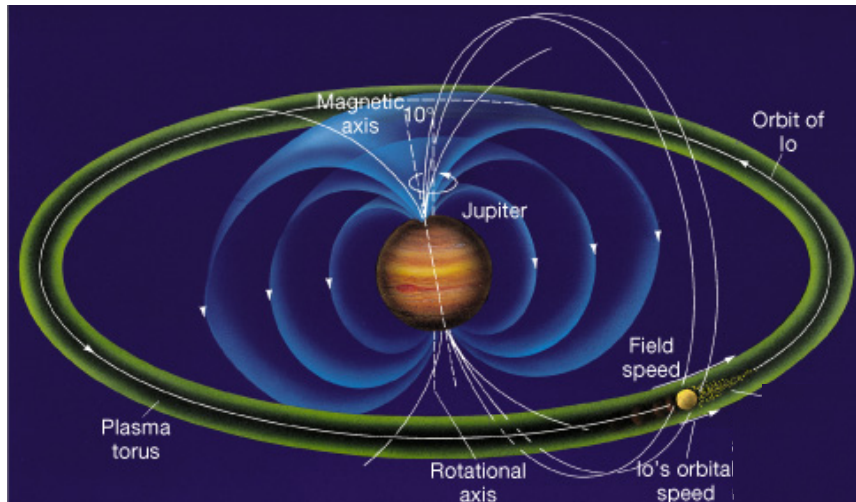

Diagram showing Jupiter's magnetic field, and the orbit of its moon Io.

The energetic charged particles in the torus make it an extremely high radiation area, lethal to either manned or unmanned space vehicles. Spectroscopic evidence of sulfur in the torus makes the volcanism of Io the likely source of the charged particles in it.

- (a) Jupiter's radius is  $6.99 \times 10^4$  km, and it has a mass of  $1.90 \times 10^{27}$  kg. Calculate the gravitational force on Io.

(4 marks)

$$F_g = G \frac{Mm}{r^2}$$

1

$$r = 5.9 \times 6.99 \times 10^7$$

1

(calculation must be shown either on its own or as part of the larger formula below)

$$F_g = 6.67 \times 10^{-11} \frac{1.90 \times 10^{27} \times 8.93 \times 10^{22}}{(5.9 \times 6.99 \times 10^7)^2}$$

1

$$F_g = 9.26 \times 10^{22} \text{ N attraction}$$

1

- (b) Io ejects electrons from its volcanoes in all directions, yet only some of these are able to interact with Jupiter's magnetic field. Explain why this is the case.

(2 marks)

- The electrons will only interact with the magnetic field if they are

---

moving perpendicular to it

- Some of the electrons emitted will be parallel to the field lines and

---

not experience a force

---

---

---

---

- (c) Io's orbit of Jupiter takes 42.0 Earth hours. Calculate the centripetal force on an electron in the torus.

(4 marks)

$$T = 42 \times 60 \times 60 = 151200 \text{ s}$$

$$V = (2\pi r) / T = (2\pi \times 5.9 \times 6.99 \times 10^7) / 151200 = 17138 \text{ ms}^{-1} \quad (1)$$

$$F_c = mv^2 / r \quad (1)$$

$$F_c = (9.11 \times 10^{-31} \times 17138^2) / (5.9 \times 6.99 \times 10^7) \quad (1)$$

$$F_c = 6.49 \times 10^{-31} \text{ N} \quad (1)$$

Some of the electrons released by Io travel at high speeds towards Jupiter. During a 15.0 s time period,  $2.60 \times 10^{26}$  electrons reach the surface of Jupiter from Io.

(d) Calculate the electric current.

(3 marks)

$$I = q/t \quad (1)$$

$$I = (2.6 \times 10^{26} \times 1.6 \times 10^{-19}) / 15 \quad (1)$$

$$I = 2.77 \times 10^6 \text{ A} \quad (1)$$

(e) Calculate the speed of the electrons.

(4 marks)

$$\text{Speed} = d / t \quad (1)$$

$$(1)$$

$$S = ((5.9 - 1) \times 6.99 \times 10^7) / 15 \quad (1)$$

$$S = 22.8 \times 10^6 \text{ ms}^{-1} \quad (1)$$

**End of Section Two**